

Molecular Physics

An International Journal at the Interface Between Chemistry and Physics

ISSN: (Print) (Online) Journal homepage: <https://www.tandfonline.com/loi/tmph20>

Sub-percent accuracy for the intensity of a near-infrared water line at $10,670\text{ cm}^{-1}$: experiment and analysis

Tom M. Rubin, Marian Sarrazin, Nikolai F. Zobov, Jonathan Tennyson & Oleg L. Polyansky

To cite this article: Tom M. Rubin, Marian Sarrazin, Nikolai F. Zobov, Jonathan Tennyson & Oleg L. Polyansky (2022) Sub-percent accuracy for the intensity of a near-infrared water line at $10,670\text{ cm}^{-1}$: experiment and analysis, Molecular Physics, 120:19-20, e2063769, DOI: [10.1080/00268976.2022.2063769](https://doi.org/10.1080/00268976.2022.2063769)

To link to this article: <https://doi.org/10.1080/00268976.2022.2063769>



© 2022 The Author(s). Published by Informa UK Limited, trading as Taylor & Francis Group.



Published online: 13 Apr 2022.



Submit your article to this journal [↗](#)



Article views: 315



View related articles [↗](#)



View Crossmark data [↗](#)

Sub-percent accuracy for the intensity of a near-infrared water line at $10,670\text{ cm}^{-1}$: experiment and analysis

Tom M. Rubin ^a, Marian Sarrazin^a, Nikolai F. Zobov ^b, Jonathan Tennyson ^c and Oleg L. Polyansky ^{b,c}

^aPTB (Physikalisch-Technische Bundesanstalt), Berlin, Germany; ^bInstitute of Applied Physics, Russian Academy of Sciences, Nizhny Novgorod, Russia; ^cDepartment of Physics and Astronomy, University College London, London, UK

ABSTRACT

Laser measurements of the intensity of $(201) 3_{22} - (000) 2_{21}$ near-infrared water absorption line at $10,670.1\text{ cm}^{-1}$ are made using three different Herriott cells. These measurements determine the line intensity with a standard deviation below of 0.3% by consideration of the new geometrically derived formula for the optical path length without approximations. This determination together with the current accepted value lead to an overall uncertainty of 0.7% of the experimentally assessed line intensity which is compared with previous *ab initio* predictions. It is found that steady improvements in both the dipole moment surface (DMS) and the potential energy surface (PES) used in the theoretical studies lead to a systematically better agreement with the observation, with the most recent prediction agreeing closely with the experiment.

ARTICLE HISTORY

Received 31 January 2022
Accepted 30 March 2022

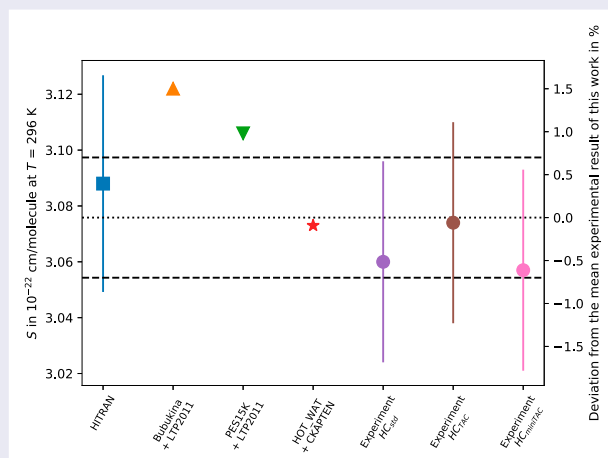



1. Introduction

All molecules can be arguably divided into three unequal categories. To the first group belong two-electron systems, such as H_2 , HHe^+ and H_3^+ . The second group comprises 10-electron systems which includes HF, water, ammonia and methane as well as H_3O^+ , NH_4^+ and CH_5^+ . The third group consists of the great multitude of remaining molecules. Why do we make such an unequal distribution? This division of species is based on the relative simplicity and importance of the species considered.

The fundamental works of Wolniewicz [1, 2] on the H_2 molecule represent the beginning of solving the

ab initio electronic structure problem for two-electron systems. Modern developments built on work by Wolniewicz [3–5] includes the papers by Pachucki, Komasa and co-workers [6–8], which demonstrate excellent continuation of Wolniewicz's earlier work. Indeed, it has been said [9–12] that state-of-the-art *ab initio* calculations [13, 14] represent a solution for the H_3^+ molecular ion, although there are a number of studies showing that further work is required on this important [15] and fundamental ion [16–24].

Ten-electron systems have a particular significance because of the importance of many of them in the

CONTACT Oleg L. Polyansky  o.polyansky@ucl.ac.uk  Department of Physics and Astronomy, University College London, Gower Street, London WC1E 6BT, UK

atmosphere of the Earth, solar system planets and exoplanets. Clearly, the *ab initio* solution for molecules, belonging to this second group requires greater computational efforts and remains much further from a satisfactory or final solution, than the for molecules belonging to the two-electron group. The *ab initio* predictions of the rovibrational energy levels of water reached the 1 cm^{-1} level in [25] and 0.1 cm^{-1} for stretching states in [26], rising to 0.3 cm^{-1} when highly excited bending modes are considered. However, there are still many improvements needed to reach the level of accuracy achieved by Wolniewicz for H_2 calculations [1, 2].

Recent focus has turned towards developing theoretical models which give accurate predictions for the transition intensities, see [27] for example. These predictions are important because experimental determinations of the many lines required for atmospheric and other models are often only accurate to a few percent. Furthermore, precise intensity measurements are suggesting novel uses for the spectroscopy of molecules [28].

However, tests of accurate ro-vibrational transition intensities require measurements with corresponding or even better accuracy. The first sub-percent agreement between theory and experiment was achieved for water line intensities in the calculations of Lodi *et al.* (LTP) [29]. The LTP dipole moment surface (DMS) was used to compute the water line intensities for comparisons with the first sub-percent accurate measurements by Hodges and Lisak [30]. However, subsequent measurements of line intensities for some other water bands [31] disagreed with the LTP predictions by up to 5%. Further improvements in the calculations resulted in the sub-percent agreement with these newly measured line intensities [32].

A detailed comparison between theoretical predictions and high accuracy measurements by Birk *et al.* [33] suggested that while agreement for some bands was satisfactory (about 1%), this was not true for all bands. In particular, Birk *et al.* found that for high overtone transitions in the near-infrared or optical theory only agreed with their near IR Fourier Transform Spectrometer (FTS) measurements with an accuracy of about 2%. Since then further improvements have been achieved in both the theoretical techniques [34] and the corresponding calculations [32, 35]. Such improvements need to be tested against ever more accurate experimental results and it is such a test that we present here.

In this paper, we present three experimental determinations of the intensity of near IR overtone line of H_2^{16}O . These measurements are compared to the generally adopted value from the FTS measurements of Birk *et al.* [33] leading to a sub-per cent uncertainty of the experimentally assessed intensity. The experimental

results are also compared to various theoretical predictions.

2. Experimental set-up

Figure 1 gives a schematic overview of the experimental set-up used to make high accuracy measurements of the intensity of the H_2^{16}O (201) $3_{22} - (000)_{221}$ line.

A tunable diode laser (Diode: Laser Components; controller: Stanford Research Systems LC501) was used to generate the IR light at $10,670\text{ cm}^{-1}$. To suppress interfering influences, such as caused by stray light, the laser beam was chopped at 2 kHz, while the five detector signals were each recorded phase-sensitive with lock-in amplifiers (Stanford Research Systems SR850). All MCT-detectors used were of the same type (Teledyne Judson HgCdTe Photodiode: J23TE2-66C-R01M). The linearity of all detectors was measured extensively beforehand with a set of neutral density filters, and no deviation was detectable even for the maximum laser power used. The possible influence of the detector nonlinearities was, therefore, considered as negligible for the uncertainty budget, being well below one percent. As illustrated in Figure 1, the two partial beams running downward were used to characterise the properties of the laser emission. Here, the first partial beam aimed at ‘Detector Laser intensity’ is used to determine the intensity fluctuations of the laser and the second partial beam downwards is used for the calibration of the frequency tuning of the laser emission by means of an unbalanced Michelson interferometer in the form of an additional Herriott cell (‘HC(Etalon)’: $\text{FSR} = 6.25 \times 10^3\text{ cm}^{-1}$). Each of the three upwards-pointing partial beams was used to probe its Herriott cell inside the vacuum chamber and was then focused onto the corresponding detector by means of an off-axis paraboloid.

The pressure inside the vacuum chamber was measured with three different gauges, depending on the pressure range: Digiquartz Model 745 from Paroscientific up to 1000 mbar, Baratron from MKS up to 13 mbar and an ionisation gauge to assess the residual pressure of 1.4×10^{-6} mbar after 12 h of evacuation. The H_2O introduced into the measurement chamber was taken from the headspace of a Mill-Q water supply limiting the maximum H_2O pressure to about 13 mbar according to the ambient temperature. The temperature of the vacuum chamber was measured with six PT100 sensors, that were connected to the chamber walls, leading to a total temperature uncertainty of $U(T) < 100\text{ mK}$ ($k=1$). The gas purity was probed with a mass spectrometer (MKS Microvision-ip1000c).

The experimentally determined H_2O line strengths were measured using three different Herriott cells to

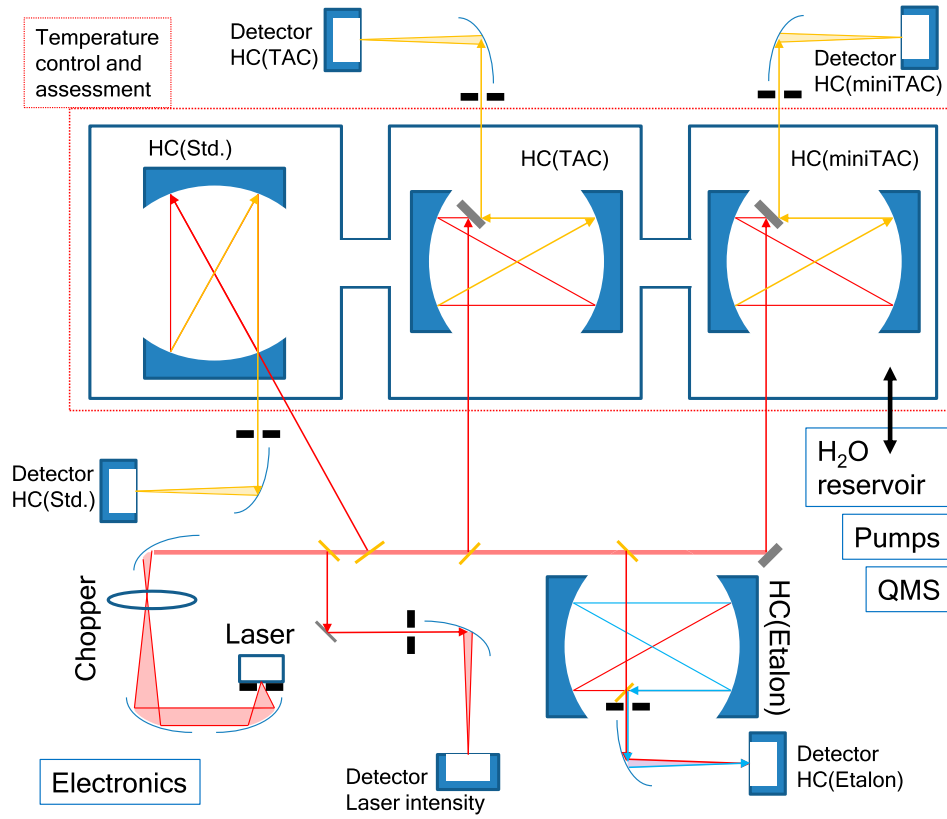

Figure 1. A schematic drawing of the experimental set-up.

Table 1. Optical path lengths for each Herriott cells (HC); N is the number of reflections and D the mirror to mirror separation.

Name of cell	D	$2N$	Opt. path (inner+outer)	Total optical path
HC _{std}	0.6664(5) m	46	30.653(25) m + 0.260(10) m	30.913(27) m
HC _{TAC}	0.8190(5) m	36	29.482(45) m + 0.480(5) m	29.962(46) m
HC _{miniTAC}	0.4038(2) m	76	30.691(42) m + 0.266(1) m	30.957(42) m

increase sensitivity due to the extended optical path length. Herriott cells consist of two spherical mirrors with concave surfaces facing each other [36, 37]. Typically, the coupling of the laser radiation used into and out of the cell is done via one or more corresponding holes in the mirrors. In the first cell ‘HC_{std}’ both occurred via the same hole in one of the two mirrors. Transverse coupling, for example, via a thin plate with reflective surfaces on both sides, is also possible and was used for the cells two: ‘HC_{TAC}’ and three: ‘HC_{miniTAC}’. The optical path length realised inside the Herriott cell for multiple reflections for a complete round trip with N reflections per mirror depends on the distance ‘ D ’ of the mirrors and their effective radii of curvature ‘ROC’. The ratio of mirror distance and radius of curvature gives information about the potentially closed configuration and the corresponding number of reflections. The geometrically derived formula

$$D = (ROC - s_{\text{corr}}) \cdot (1 - \cos(\pi U/N)) + 2s_{\text{corr}} \quad (1)$$

describes exactly for which mirror distances closed configurations exist. Here, U describes the number of 2π -twists with respect to the centre line between the two Herriott cell mirrors and s_{corr} is given by $s_{\text{corr}} = ROC - \sqrt{ROC^2 - r_{\text{sp}}^2}$, with r_{sp} as the radius of the spot patterns generated on the mirrors. More details are given by Rubin [38]. The optical path lengths used are specified in Table 1.

3. Line intensity measurement results

The H₂O absorption line strength measurements were made at 296 K. Accordingly, the line strength was determined with the following formula:

$$S(296 \text{ K}) = S(T) \cdot (1 - 2.2 \cdot 10^{-3}) \cdot (T - 296 \text{ K}). \quad (2)$$

The H₂O pressure range between 0 mbar and 13 mbar was covered leading to the results listed in Table 2.

Table 2. Measured line intensities at 296 K of the water absorption line at $10,670.1\text{ cm}^{-1}$.

Herriott cell	Measured intensity
HC _{std}	$3.060(36) \cdot 10^{-22}\text{ cm/molecule}$
HC _{TAC}	$3.074(36) \cdot 10^{-22}\text{ cm/molecule}$
HC _{miniTAC}	$3.057(36) \cdot 10^{-22}\text{ cm/molecule}$

Table 3. Quantities and uncertainty contributions (with $k = 1$) for the measured line strength intensities leading to a relative uncertainty of $u(S) = 1.16\%$.

Quantity	Value	Uncertainty contribution
Integrated absorption	na	1%
Partial pressure	99.73% of 0–13 mbar	0.5%
Optical path length	30 m	0.3%
Temperature (T)	296.0 K	$3.4 \cdot 10^{-4}$
Second density virial coefficient (B(T))	$-34\text{ cm}^3/\text{mol}$	$< 10^{-4}$
Residual pressure	$< 1.4 \cdot 10^{-6}\text{ mbar}$	$< 10^{-4}$

Table 3 lists the quantities and uncertainty contributions used to estimate the uncertainty in the H_2O absorption line strength assessments.

4. Calculation of line intensities

There have been a series of efforts to improve predicted intensities [39–45]. The studies rely on the accurate solution of the nuclear-motion Schrödinger equation, the use of high quality potential energy surface (PESs), and dipole moment surfaces (DMSs) from *ab initio* electronic structure calculations. For the DMS, the calculation of *ab initio* values at multiple geometries and subsequent fitting of these points to the analytical form to reproduce these points with the typical accuracy of 1×10^{-5} Debye is a standard procedure. For the PES just the *ab initio* calculations of the points and their fit to the corresponding analytical form is not sufficient. As shown in [46], the improvement of the PES from one which can be used to reproduce the rovibrational energy levels of water with an accuracy of 0.1 cm^{-1} to one giving differences of 0.025 cm^{-1} can change the values of the calculated intensities by up to 2%. At present, no purely *ab initio* PES reproduces the observed ro-vibrational energy levels of water to better than 0.1 cm^{-1} . For this reason the procedure of starting from a high quality *ab initio* PES and then improving it by fitting to the experimental energy levels has been widely adopted [35, 46–51]. For H_2^{16}O , this technique has been used to give close to experimental accuracy of 0.01 cm^{-1} [35, 46]. As shown below, such an accuracy is important for obtaining subsequent sub-percent accuracy in line intensity calculations.

In this work we compare results of three attempts to make high accuracy predictions of H_2^{16}O line intensities.

The first of these used the ‘Bubukina’ PES of Bubukina *et al.* [50] constructed by fitting to ro-vibrational energy levels up to $25,000\text{ cm}^{-1}$, which were reproduced with a standard deviation of 0.022 cm^{-1} . The second PES is the improved PES15K [46] which only fitted to ro-vibrational energy levels below $15,000\text{ cm}^{-1}$, which were reproduced with an accuracy of 0.011 cm^{-1} . The improved PES15K PES has already been shown to result in a significant improvement of the calculated intensities [46]. Finally, we consider the recently constructed HOT_WAT PES of Conway *et al.* [35] fitted ro-vibrational energies over the entire range of their availability which is almost up to dissociation [52]. We note that the transition frequency of the line at $10,670.1\text{ cm}^{-1}$ discussed in the present paper is reproduced best by this PES to within only 0.001 cm^{-1} .

Experience has shown that it is best to use *ab initio* DMSs [53]. There has been a steady improvement in both calculation and fitting *ab initio* DMSs over the years [29, 32, 54–56]. Here, we consider the LTP2011 DMS of LTP [29] which is based on a set of 2000 internally contracted multi-reference configuration interaction (IC-MRCI) points calculated with an aug-cc-pCV6Z basis set as energy derivatives (ED). Relativistic corrections to the dipoles were obtained in a similar manner by computing the derivatives with respect to the external electric field strength of the mass-velocity, one-electron Darwin (MVD1) relativistic corrections to the IC-MRCI energies. This DMS gives sub-percent accuracy for some bands but has been shown to give predictions a few percent off for some bands [33]. Second, we consider the CKAPTEN DMS of Conway *et al.* [32] which was calculated using a similar procedure but with relativistic corrections obtained using a Douglas–Kroll–Hess Hamiltonian to order two (DKH2). The number of points were significantly increased to about 17500 and an improved fit function used giving a better overall fit. For HOT_WAT and CKAPTEN, the average deviation of the predicted intensities for the (201) band considered here compared to the measured transition intensities of Birk *et al.* [33] is only 0.4%.

5. Comparison with theoretical calculations

The comparison between our measurements and the theoretical calculations described above are given in Table 4 and Figure 2. The first row compares the three measurements of this work with the value recommended in the HITRAN database [57], which actually comes from the FTS measurements of Birk *et al.* [33] and has uncertainty of 1%. The current measured results considering the new formula for the optical path length have a mean value of $3.064 \times 10^{-22}\text{ cm/molecule}$ with a standard deviation of 0.3%. Since most of their uncertainty contributions

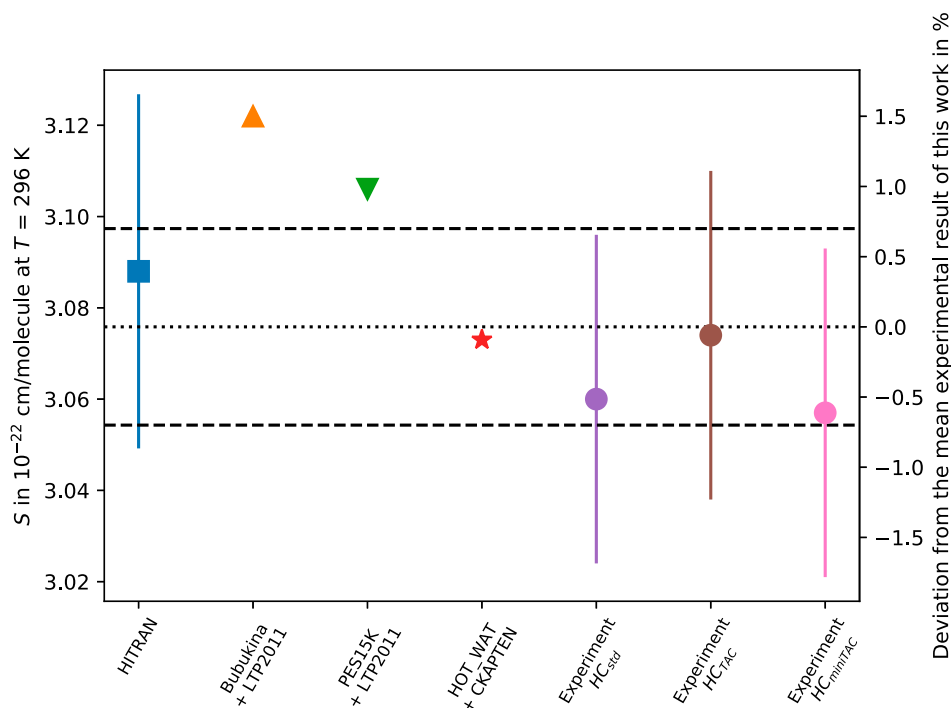

Figure 2. Comparison of measured intensities and theoretical calculations. The dashed horizontal lines represent the mean experimentally assessed line strength of $S(293\text{ K}) = 3.076 \times 10^{-22}$ cm/molecule with a standard uncertainty of 0.7%.

Table 4. Comparison of the combined experimental result with the theoretical calculations. Intensities, S , at 296 K are given in units of 10^{-22} cm/molecule.

Frequency cm^{-1}	S	PES	DMS	Exp	o/c %
10,670.122	3.088 ^a			3.076	-0.4
10,670.112	3.112	Bubukina [50]	LTP2011 [29]	3.076	-1.2
10,670.115	3.106	PES15K [46]	LTP2011 [29]	3.076	-1.0
10,670.121	3.073	HOT_WAT [35]	CKAPTEN [32]	3.076	0.1

^aValue from HITRAN [57].

are considered as ‘type B’ uncertainties with respect to the GUM (Guide to the expression of uncertainty in measurement), the combined value (literature plus the current three results) for the experimentally assessed line strength is 3.076×10^{-22} cm/molecule with a standard uncertainty of 0.7%.

The final three rows of Table 4 compare with theoretical predictions. The first two of these both use the LTP2011 DMS [46]; agreement improves with use of the better wavefunctions generated using the more accurate PES15K PES. The final row compares with the most recent result using both an improved PES and the CKAPTEN DMS [32]. The intensity predicted with these calculations lies within the experimental uncertainties and differ by less than 0.1% from the mean measured value. The use of the CKAPTEN DMS gives a significant improvement over LTP2011.

This is a first step and is very important, though clearly we need the expansion in two directions. First, the measurements of intensities of more lines, belonging to the different vibrational bands. Second, the higher overtones

journey towards higher frequencies from near IR towards optical region and even UV with the sub-percent accuracy is necessary.

6. Conclusions

We present new accurate measurements of the intensity of the $3_{22} - 2_{21}$ water absorption line in the (201) band at $10,670.1\text{ cm}^{-1}$. The combined measurement result gives an intensity $S(293\text{ K}) = 3.076 \times 10^{-22}$ cm/molecule with an uncertainty of 0.7%. Comparisons with high level theoretical predictions of this transition intensity show systematically improved agreement as the level of theoretical treatment of both the dipole moment and potential energy surfaces are improved. The best calculation gives predictions which lie within the experimental uncertainty. This comparison suggests that the most recent theory is able to provide excellent results for higher stretching overtone although further high accuracy experimental studies would be needed to confirm this situation. The next step is to

extend this work to higher overtones and frequencies extending into the optical region and even the near-UV. In this context, we note that recent cavity ring down spectroscopy measurements by Vasilchenko *et al.* [58] suggest that further work is needed to get equally reliable predicted intensities for the very weak bending overtones in the red region of spectrum.

Disclosure statement

No potential conflict of interest was reported by the authors.

Funding

We acknowledge support by State Project IAP RAS No. 0030-2021-0016 and ERC Advanced Investigator Project 883830. T.M.R. and O.L.P. acknowledge support from the QuantumPascal project 18SIB04, which has received funding from the EMPIR programme co-financed by the Participating States and from the European Union's Horizon 2020 research and innovation programme.

ORCID

Tom M. Rubin  <http://orcid.org/0000-0002-6794-5071>

Nikolai F. Zobov  <http://orcid.org/0000-0003-4126-0346>

Jonathan Tennyson  <http://orcid.org/0000-0002-4994-5238>

Oleg L. Polyansky  <http://orcid.org/0000-0002-7127-3271>

References

- [1] L. Wolniewicz, *J. Chem. Phys.* **99**, 1851 (1993). doi:10.1063/1.465303
- [2] L. Wolniewicz, *J. Chem. Phys.* **103**, 1792 (1995). doi:10.1063/1.469753
- [3] L. Wolniewicz and J. Hinze, *J. Chem. Phys.* **101**, 9817 (1994). doi:10.1063/1.467947
- [4] A. Alijah, J. Hinze and L. Wolniewicz, *Methods Protoc.* **85**, 1105 (1995). doi:10.1080/00268979500101701
- [5] A. Alijah, L. Wolniewicz and J. Hinze, *Methods Protoc.* **85**, 1125 (1995). doi:10.1080/00268979500101711
- [6] K. Pachucki and J. Komasa, *J. Chem. Phys.* **130**, 164113 (2009). doi:10.1063/1.3114680
- [7] J. Komasa, K. Piszczatowski, G. Lach, M. Przybytek, B. Jeziorski and K. Pachucki, *J. Chem. Theory Comput.* **7**, 3105 (2011). doi:10.1021/ct200438t
- [8] J. Rychlewski, W. Cencek and J. Komasa, *Chem. Phys. Lett.* **229**, 657–660 (1994). doi:10.1016/0009-2614(94)01108-7
- [9] S. Mielke, K. Peterson, D. Schwenke, B. Garrett, D. Truhlar, J. Michael, M. Su and J. Sutherland, *Phys. Rev. Lett.* **91**, 063201 (2003). doi:10.1103/PhysRevLett.91.063201
- [10] C. Jungen and S.T. Pratt, *Phys. Rev. Lett.* **102**, 023201 (2009). doi:10.1103/PhysRevLett.102.023201
- [11] J. Varju, M. Hejduk, P. Dohnal, M. Jilek, T. Kotrik, R. Plasil, D. Gerlich and J. Glosik, *Phys. Rev. Lett.* **106**, 203201 (2011). doi:10.1103/PhysRevLett.106.203201
- [12] H. Chen, C. Hsiao, J. Peng, T. Amano and J. Shy, *Phys. Rev. Lett.* **109**, 263002 (2012). doi:10.1103/PhysRevLett.109.263002
- [13] O.L. Polyansky and J. Tennyson, *J. Chem. Phys.* **110**, 5056 (1999). doi:10.1063/1.478404
- [14] J. Tennyson, P. Barletta, M.A. Kostin, O.L. Polyansky and N.F. Zobov, *Spectrochim. Acta A* **58**, 663 (2002). doi:10.1016/S1386-1425(01)00663-1
- [15] S. Miller, T.R. Geballe, T. Stallard and J. Tennyson, *Rev. Mod. Phys.* **92**, 035003 (2020). doi:10.1103/RevModPhys.92.035003
- [16] M. Pavanello, L. Adamowicz, A. Alijah, N.F. Zobov, I.I. Mizus, O.L. Polyansky, J. Tennyson, T. Szidarovszky, A.G. Császár, M. Berg and A. Petrigiani, *Phys. Rev. Lett.* **108**, 023002 (2012). doi:10.1103/PhysRevLett.108.023002
- [17] M. Pavanello, L. Adamowicz, A. Alijah, N.F. Zobov, I.I. Mizus, O.L. Polyansky, J. Tennyson, T. Szidarovszky and A.G. Császár, *J. Chem. Phys.* **136**, 184303 (2012). doi:10.1063/1.4711756
- [18] L.G. Diniz, J.R. Mohallem, A. Alijah, M. Pavanello, L. Adamowicz, O.L. Polyansky and J. Tennyson, *Phys. Rev. A* **88**, 032506 (2013). doi:10.1103/PhysRevA.88.032506
- [19] L. Lodi, O.L. Polyansky, A.A.J. Tennyson and N.F. Zobov, *Phys. Rev. A* **89**, 032505 (2014). doi:10.1103/PhysRevA.89.032505
- [20] A. Alijah, J. Fremont and V.G. Tyuterev, *Phys. Rev. A* **92**, 012704 (2015). doi:10.1103/PhysRevA.92.012704
- [21] M. Marquez-Mijares, O. Roncero, P. Villarreal and T. Gonzalez-Lezana, *Few-Body Syst.* **59**, 14 (2018). doi:10.1007/s00601-018-1332-8
- [22] A. Muolo, E. Matyus and M. Reiher, *J. Chem. Phys.* **149**, 184105 (2018). doi:10.1063/1.5050462
- [23] A. Muolo, E. Mátyus and M. Reiher, *J. Chem. Phys.* **151**, 154110 (2019). doi:10.1063/1.5121318
- [24] R. Jaquet and M. Lesiuk, *J. Chem. Phys.* **152**, 104109 (2020). doi:10.1063/1.5144293
- [25] O.L. Polyansky, A.G. Császár, S.V. Shirin, N.F. Zobov, P. Barletta, J. Tennyson, D.W. Schwenke and P.J. Knowles, *Science* **299**, 539 (2003). doi:10.1126/science.1079558
- [26] O.L. Polyansky, R.I. Ovsyannikov, A.A. Kyuberis, L. Lodi, J. Tennyson and N.F. Zobov, *J. Phys. Chem. A* **117**, 9633–9643 (2013). doi:10.1021/jp312343z
- [27] L. Lodi and J. Tennyson, *J. Quant. Spectrosc. Radiat. Transf.* **113**, 850 (2012). doi:10.1016/j.jqsrt.2012.02.023
- [28] K. Jousten, J. Hendricks, D. Barker, K. Douglas, S. Eckel, P. Egan, J. Fedchak, J. Flügge, C. Gaiser, D. Olson and J. Ricker, *Metrologia* **54**, S146 (2017). doi:10.1088/1681-7575/aa8a4d
- [29] L. Lodi, J. Tennyson and O.L. Polyansky, *J. Chem. Phys.* **135**, 034113 (2011). doi:10.1063/1.3604934
- [30] D. Lisak, D.K. Havey and J.T. Hodges, *Phys. Rev. A* **79**, 052507 (2009). doi:10.1103/PhysRevA.79.052507
- [31] V.T. Sironneau and J.T. Hodges, *J. Quant. Spectrosc. Radiat. Transf.* **152**, 1 (2015). doi:10.1016/j.jqsrt.2014.10.020
- [32] E.K. Conway, A.A. Kyuberis, O.L. Polyansky, J. Tennyson and N. Zobov, *J. Chem. Phys.* **149**, 084307 (2018). doi:10.1063/1.5043545
- [33] M. Birk, G. Wagner, J. Loos, L. Lodi, O.L. Polyansky, A.A. Kyuberis, N.F. Zobov and J. Tennyson, *J. Quant. Spectrosc. Radiat. Transf.* **203**, 88 (2017). doi:10.1016/j.jqsrt.2017.03.040
- [34] E.K. Conway, I.E. Gordon, O.L. Polyansky and J. Tennyson, *J. Chem. Phys.* **152**, 024105 (2020). doi:10.1063/1.5135931

- [35] E.K. Conway, I.E. Gordon, J. Tennyson, O.L. Polyansky, S.N. Yurchenko and K. Chance, *Atmos. Chem. Phys.* **20**, 10015 (2020). doi:10.5194/acp-20-10015-2020
- [36] D. Herriott, H. Kogelnik and R. Kompfner, *Appl. Opt.* **3**, 523 (1964). doi:10.1364/AO.3.000523
- [37] D.R. Herriott and H.J. Schulte, *Appl. Opt.* **4**, 883 (1965). doi:10.1364/AO.4.000883
- [38] T.M. Rubin, Ph.D. thesis, Freie Universität Berlin, (2017). doi:10.17169/refubium-6520
- [39] S. Langhoff and J. Bauschlicher, *J. Chem. Phys.* **102**, 5220 (1995). doi:10.1063/1.469247
- [40] D.W. Schwenke and H. Partridge, *J. Chem. Phys.* **113**, 6592 (2000). doi:10.1063/1.1311392
- [41] X. Huang, R. Freedman, S. Tashkun, D. Schwenke and T. Lee, *J. Quant. Spectrosc. Radiat. Transf.* **130**, 134–46 (2013). doi:10.1016/j.jqsrt.2013.05.018
- [42] A. Nikitin, M. Rey and V. Tyuterev, *Chem. Phys. Lett.* **565**, 5 (2013). doi:10.1016/j.cplett.2013.02.022
- [43] G. Li, I. Gordon, L. Rothman, Y. Tan, S.-M. Hu, S. Kassi, A. Campargue and E. Medvedev, *Astrophys. J. Suppl. Ser.* **216**, 15 (2015). doi:10.1088/0067-0049/216/1/15
- [44] V. Tyuterev, A. Barbe, D. Jacquemart, C. Janssen, S. Mikhailenko and E. Starikova, *J. Chem. Phys.* **150**, 184303 (2019). doi:10.1063/1.5089134
- [45] J. Chang, L. Guo, R. Wang, J. Mou, H. Ren, J. Ma and H. Guo, *J. Phys. Chem. A* **123**, 4232 (2019). doi:10.1021/acs.jpca.9b02662
- [46] I.I. Mizus, A.A. Kyuberis, N.F. Zobov, V.Y. Makhnev, O.L. Polyansky and J. Tennyson, *Philos. Trans. R. Soc. Lond. A* **376**, 20170149 (2018). doi:10.1098/rsta.2017.0149
- [47] D.W. Schwenke, *J. Phys. Chem. A* **105**, 2352 (2001). doi:10.1021/jp0032513
- [48] S.V. Shirin, O.L. Polyansky, N.F. Zobov, P. Barletta and J. Tennyson, *J. Chem. Phys.* **118**, 2124 (2003). doi:10.1063/1.1532001
- [49] S.V. Shirin, N.F. Zobov, R.I. Ovsyannikov, O.L. Polyansky and J. Tennyson, *J. Chem. Phys.* **128**, 224306 (2008). doi:10.1063/1.2927903
- [50] I. Bubukina, N. Zobov, O. Polyansky, S. Shirin and S. Yurchenko, *Opt. Spectrosc.* **110**, 160–166 (2011). doi:10.1134/S0030400X11020032
- [51] O.L. Polyansky, A.A. Kyuberis, N.F. Zobov, J. Tennyson, S.N. Yurchenko and L. Lodi, *Mon. Not. R. Astron. Soc.* **480**, 2597 (2018). doi:10.1093/mnras/sty1877
- [52] T. Furtenbacher, R. Tóbiás, J. Tennyson, O.L. Polyansky and A.G. Császár, *J. Phys. Chem. Ref. Data* **49**, 033101 (2020). doi:10.1063/5.0008253
- [53] L. Lodi and J. Tennyson, *J. Phys. B* **43**, 133001 (2010). doi:10.1088/0953-4075/43/13/133001
- [54] H. Partridge and D.W. Schwenke, *J. Chem. Phys.* **106**, 4618 (1997). doi:10.1063/1.473987
- [55] D.W. Schwenke and H. Partridge, *J. Chem. Phys.* **113**, 6592 (2000). doi:10.1063/1.1311392
- [56] L. Lodi, R.N. Tolchenov, J. Tennyson, A.E. Lynas-Gray, S.V. Shirin, N.F. Zobov, O.L. Polyansky, A.G. Császár, J. van Stralen and L. Visscher, *J. Chem. Phys.* **128**, 044304 (2008). doi:10.1063/1.2817606
- [57] I.E. Gordon, L.S. Rothman, R.J. Hargreaves, R. Hashemi, E.V. Karlovets, F.M. Skinner, E.K. Conway, C. Hill, R.V. Kochanov, Y. Tan and P. Wcisło, *J. Quant. Spectrosc. Radiat. Transf.* **277**, 107949 (2022). doi:10.1016/j.jqsrt.2021.107949
- [58] S. Vasilchenko, S.N. Mikhailenko and A. Campargue, *J. Quant. Spectrosc. Radiat. Transf.* **275**, 107847 (2021). doi:10.1016/j.jqsrt.2021.107847